

DBCRSSM

# Cross Merch Shelving Unit **USER MANUAL**

# DANDELION

RESPONSIBLY CREATING BETTER PRODUCTS FOR A BETTER WORLD



# Table of Contents

Page 3 .....	Parts Diagram
Page 4.....	Assembly Instructions
Page 9 .....	Contact Information

# USER MANUAL

A. SIDE PANEL x2

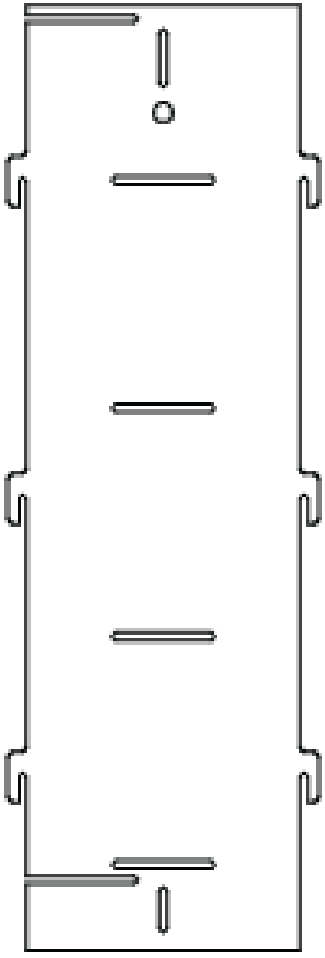

B. SHELF SUPPORT FRAME x4

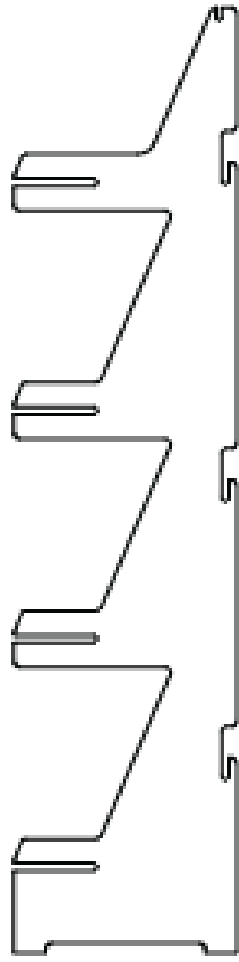

C. BASE PANEL x2

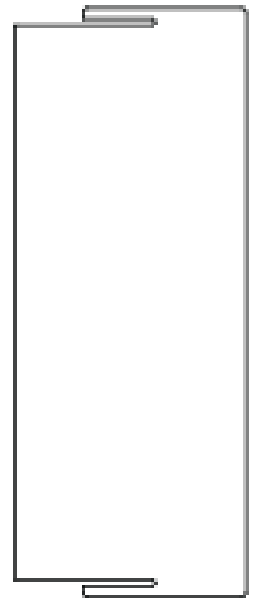

D. HEADER x2



G LOWER SUPPORT BEAM x1



H. UPPER SUPPORT BEAM x1

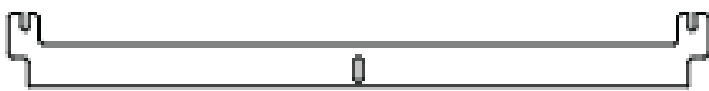

I. HANGING ROD x1



E. SHELF x8

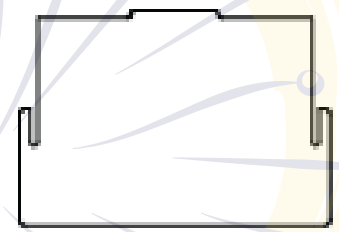

F. HANGING ROD STABILIZER x1



**NOTE: 2 persons required for assembly**  
Recommended: Rubber Mallet (not included)

# PARTS DIAGRAM

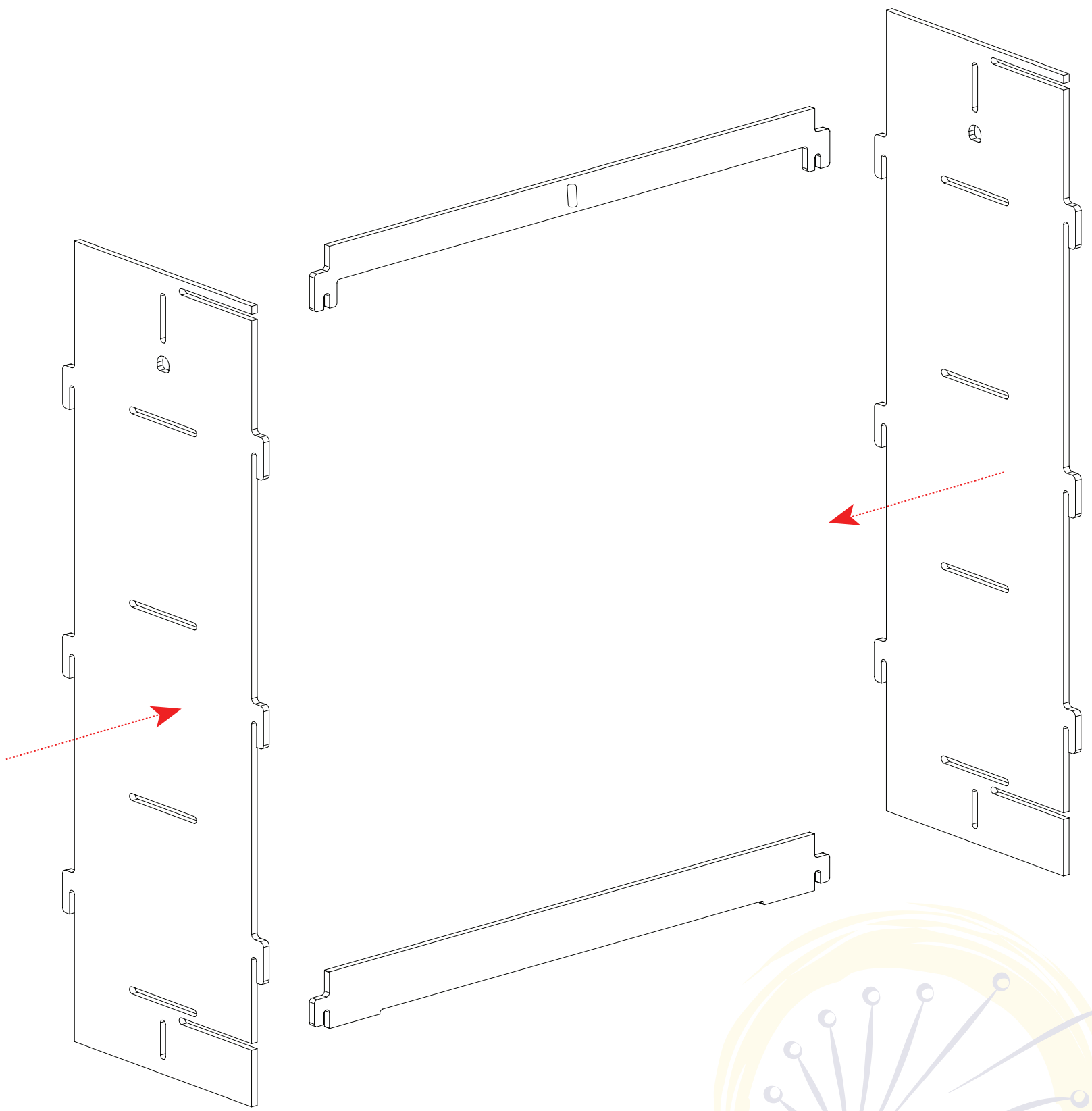

1. Have one person hold both Side Panels (A) parallel. Insert Lower Support Beam (G) into the lower slots of the side panels. Press down to secure.
2. Insert Upper Support Beam (H) into the top slots of the side panels until it locks into place. Press down to secure.

# ASSEMBLY INSTRUCTIONS

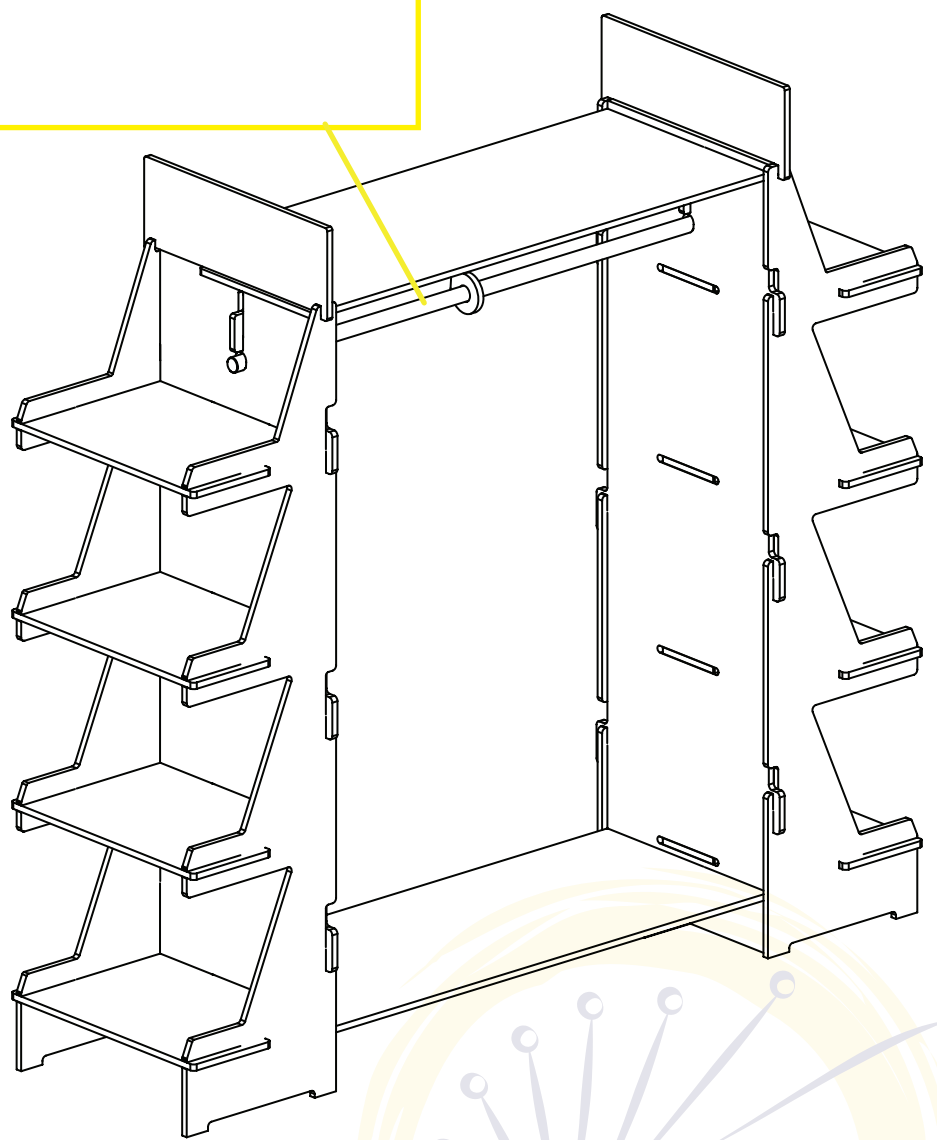
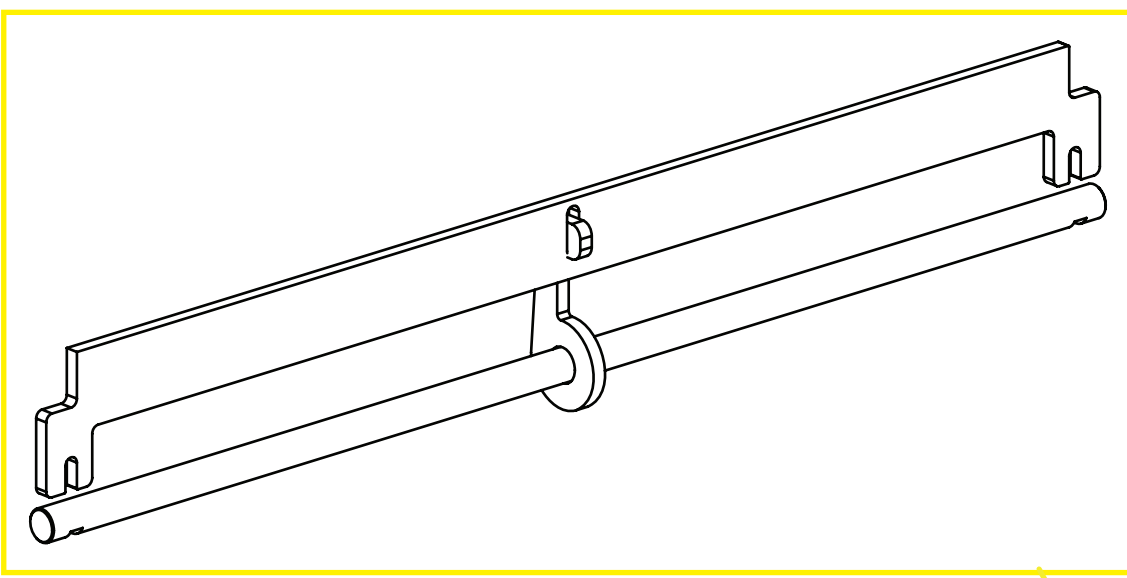

3. Slide Hanging Rod (I) in the slot of one side panel so it is half-way inserted in the unit. Slide Hanging Rod Stabilizer (F) onto rod.

Then, slide rod through the hole of the other side panel. Rotate the rod so that it aligns with the notches of the side panels. Press down to secure.

Hook the rod stabilizer into the center slot of the top support beam.

# ASSEMBLY INSTRUCTIONS

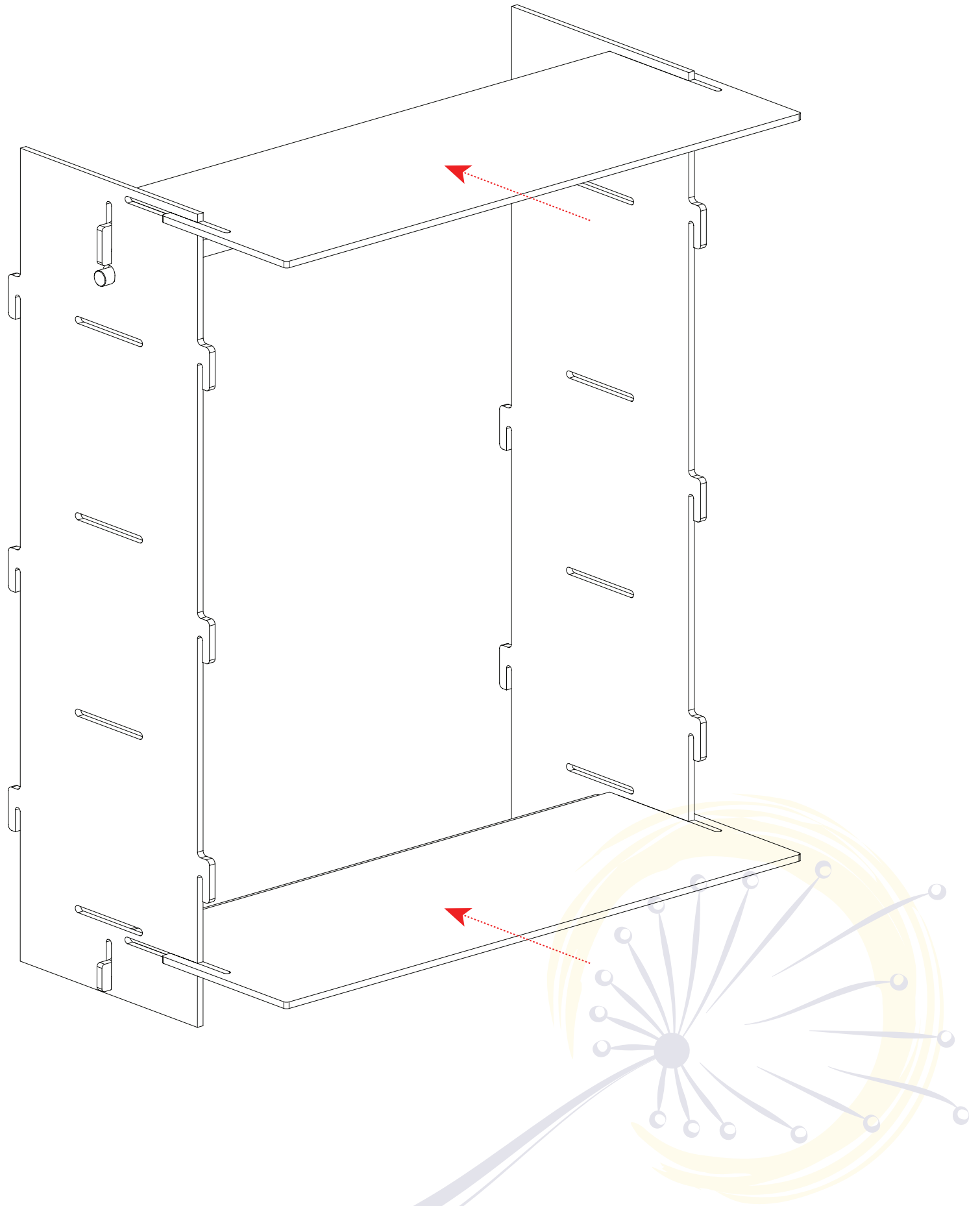

4. Firmly insert Base Panels (C) into top and bottom. Secure with a rubber mallet (not included).

# ASSEMBLY INSTRUCTIONS

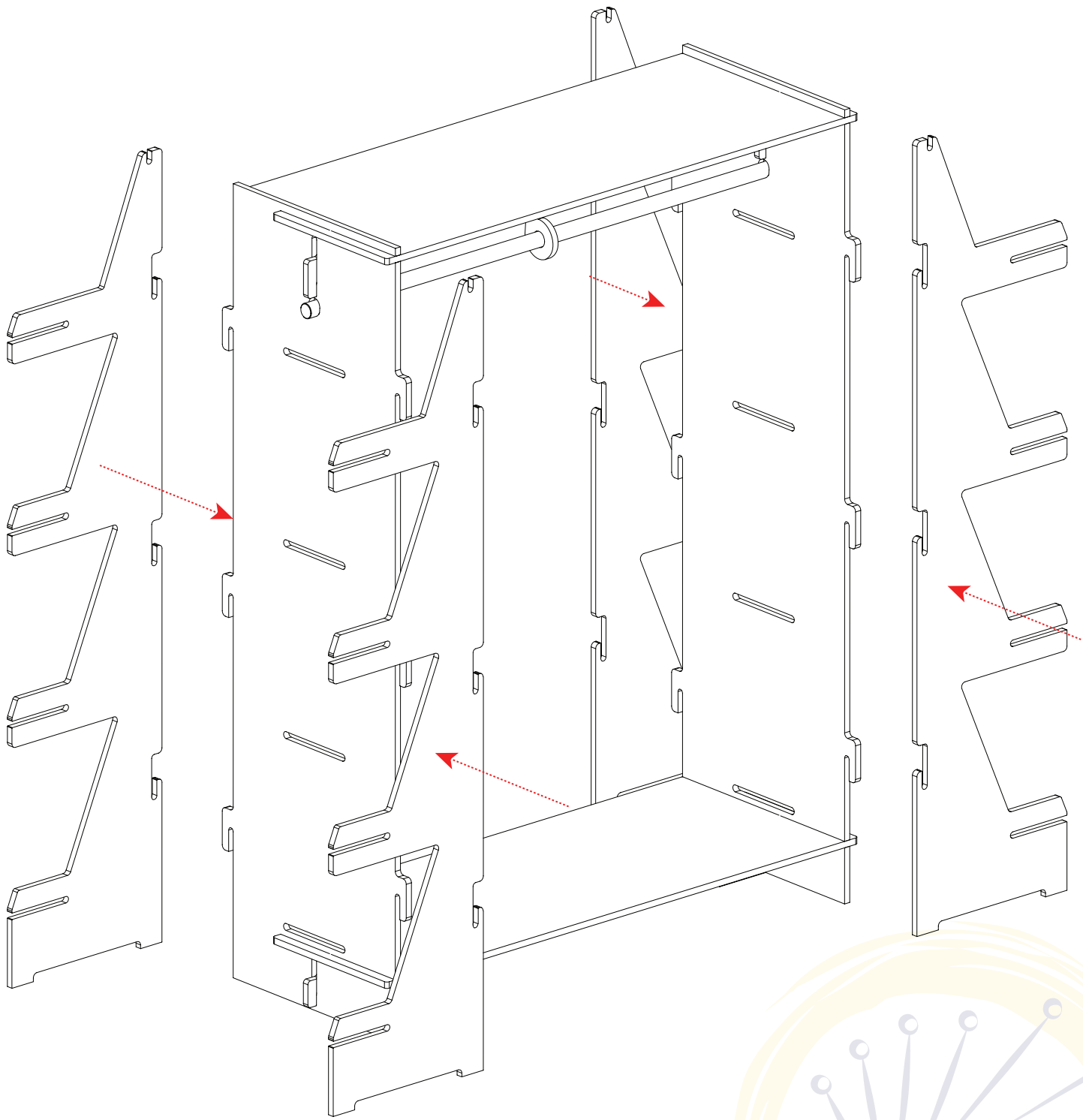

5. To add the Shelf Support Frames (B), first have one person tip the unit upwards. Slide the frame onto the notches, then lower it into the slot until it is firmly in place.

Repeat this process on each side.

# ASSEMBLY INSTRUCTIONS

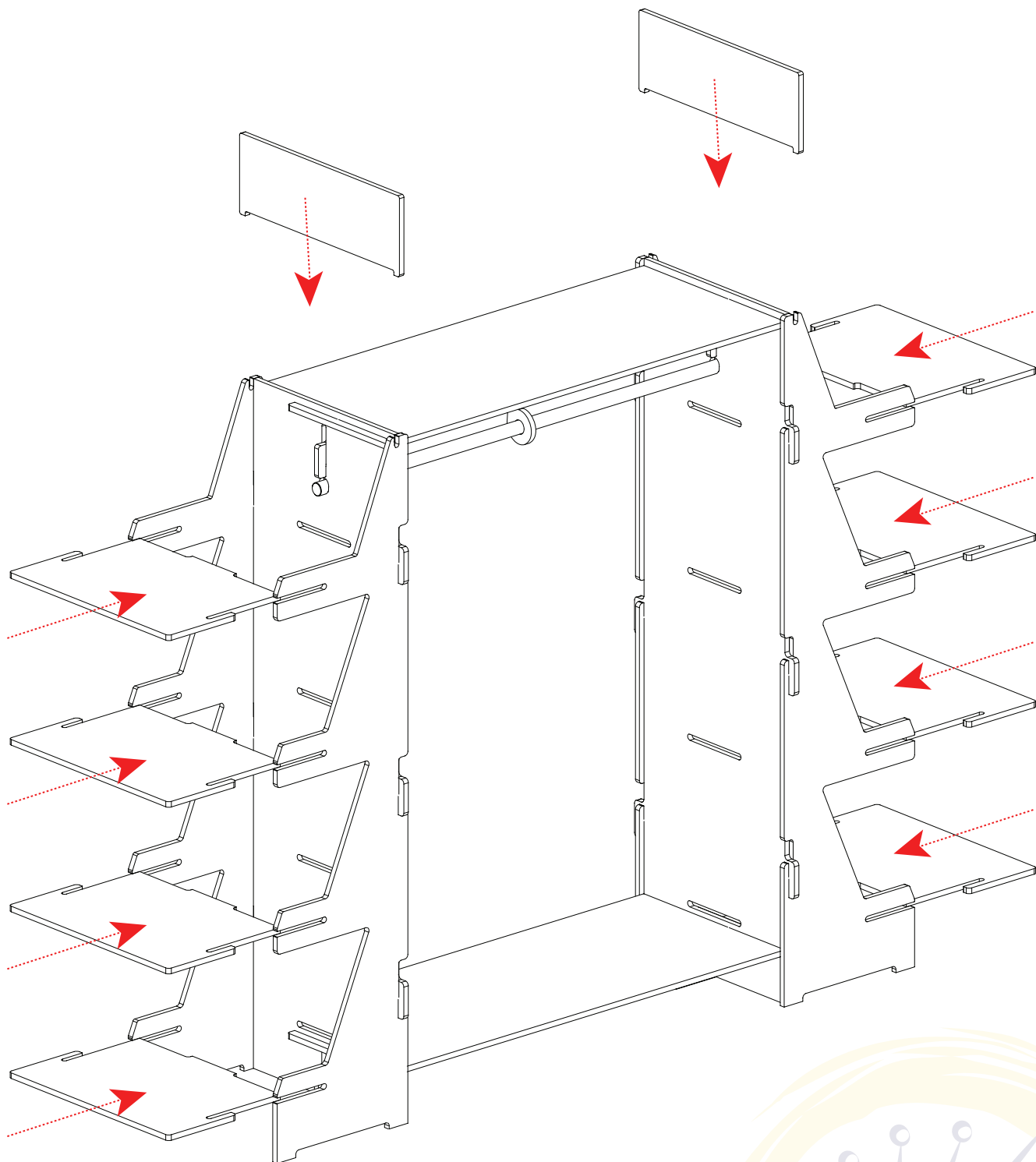

6. Insert Headers (D) into slots of top base panel, securing with a rubber mallet (not included).

7. Slide Shelves (E) into shelf support frames on each side of the unit. Tighten connections with a rubber mallet until the shelves are firmly in place.

The assembly is complete!

# ASSEMBLY INSTRUCTIONS



THANK YOU FOR  
MAKING A SUSTAINABLE  
CHOICE FOR A BRIGHTER  
FUTURE.



HAVING TROUBLE WITH THIS PRODUCT?  
CALL OUR CUSTOMER SERVICE LINE AT:  
844-221-3388

**CONTACT US**